



WB10 WiFi+Bluetooth

Wireless Adapter User Guide

Date	Supported IP Phone	Writer	Version
Aug.10th,2022	C64/C66 Series IP Phone	Ellie Zhang	0.9

1 Overview

1.1 Introduction

Dinstar WB10 WIFI+Bluetooth Wireless Adapter supports Plug-and-Play, 802.11N wireless devices and is also backward compatible with 802.11 B/G/N. The WIFI transmission rate can up to 150Mbps, making it possible to transmit multiple HD streams simultaneously within the home or office environment. The IP Phone with Bluetooth 4.0 adapter is compatible with multi-brand Bluetooth headsets, enabling users to answer/hang up calls wirelessly in the Bluetooth communication range.

WB10 also uses advanced WPA and WPA2 encryption technology, supports AES and TKIP encryption methods, and can provide worldwide channel range adjustment. Performance of multimedia transmission is greatly enhanced and improved in both Bluetooth and WLAN modes. Therefore, WB10 provides users with a convenient, secure, high-speed wireless network connection, ensures making daily voice calls smoother and more secure in an office environment.

1.2 Features

1.2.1 Key Features

- Compatible with Dinstar IP Phone C64G/C64GP-C66G/C66GP
- Reliable Connection
- High Transmission Rate, Plug and Play
- Supports 802.11N wireless devices, Compatible with 802.11 B/G/N
- Supports WPA, WPA2, Hardware-based AES and TKIP
- Supports Adaptive Frequency Hopping
- Perfectly compatible with Bluetooth v4.0+EDR
- Compatible with Bluetooth v1.1 and v1.2

1.2.2 BlueTooth

- Bluetooth specification: V4.0
- Transmission Distance: 10m
- Answer a new call through using Bluetooth headset
- End a new call through using Bluetooth headset
- Adaptive Frequency Hopping

- Maximum RF Power: 10dBm
- Transmission Speed: 3M/S

1.2.3 WiFi

- Wireless Standard: IEEE 802.11 b/g/n, CSMA/CA with ACK
- Transmission Rate:
 - 802.11b: 1/2/5.5/11Mbps
 - 802.11g: 6/9/12/18/24/36/48/54Mbps
 - 802.11n: 150Mbps
- Frequency Range: 2.4 ~ 2.4835GHz
- Transmission Distance: Up to 100m indoor, Up to 200m outdoor
- Antenna Type: Integrated
- Encryption: WEP, WPA/WPA2, 802.11i, 802.11x

1.2.4 Physical Characters

- Dimension(L*W*H): 16mm*8m*32mm
- Operating Temperature: -20 °C ~ 45 °C
- Storage Temperature: -40 °C ~70 °C
- Operating Humidity: 10%-90% Non-Condensing
- Storage Humidity: 5%-90% Non-Condensing
- Operating Current: 5V=100mA~200mA (Bluetooth+WiFi)
- Power Consumption: 0.5W~1W (Bluetooth+WiFi)

2 How to use WIFI+Bluetooth adapter

Before connecting IP phone to the current wireless network or bluetooth headset, please make sure that your phone is powered on and the system boots up.

2.1 Installing the adapter on the phone

1. Insert the WIFI+Bluetooth adapter into the USB port of the phone.

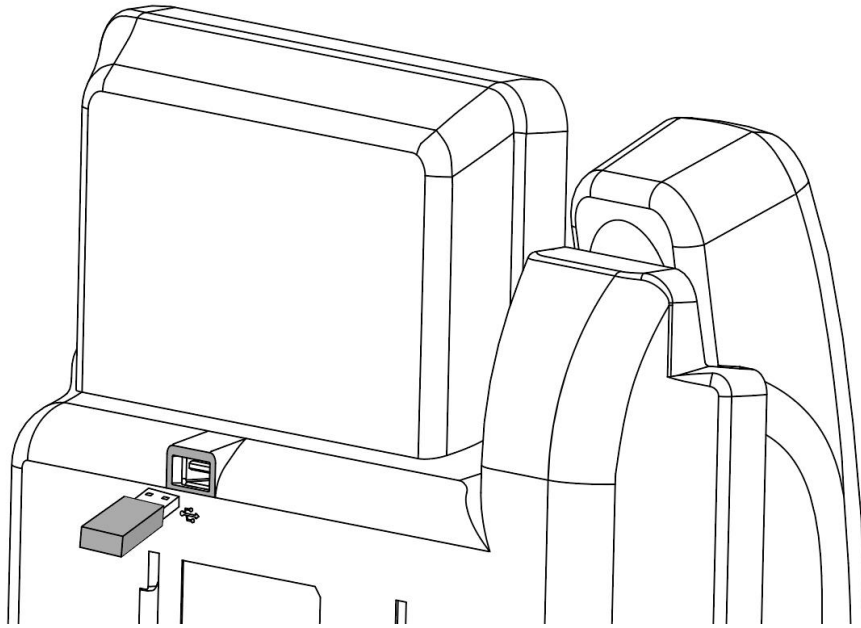

Figure 2-1

2.2 Connecting IP phone to Available Wireless Network

2.2.1 Configuring the WiFi Network through IP Phone (take C66 IP phone for example)

1. After inserting the WiFi+Bluetooth adapter into the USB port of the IP Phone. The screen will pop up a prompt message “USB adapter has been inserted, Scan Network?” ;

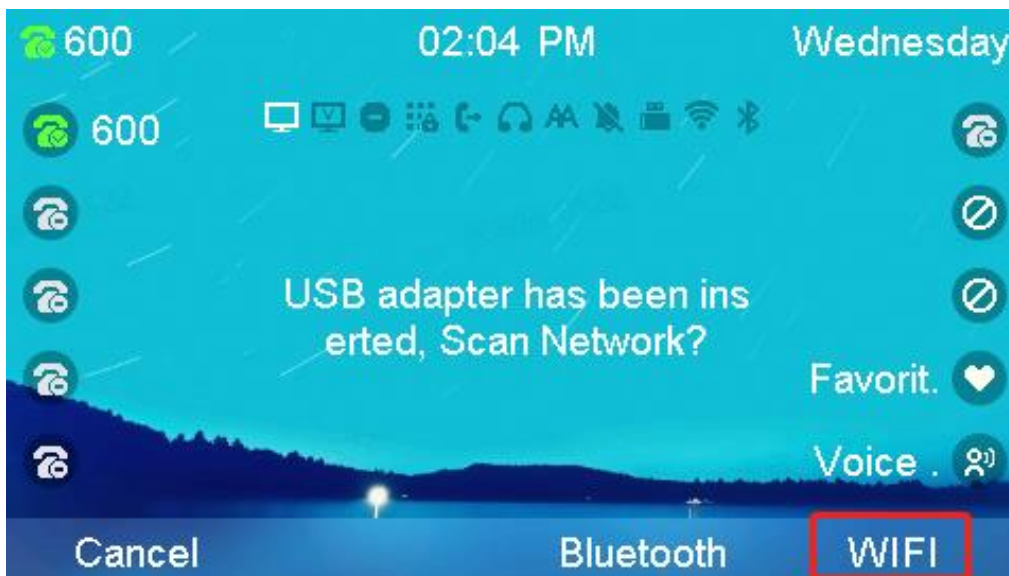

Figure 2.2-1

2. Press the *WiFi* key, enter into the WiFi network Menu;

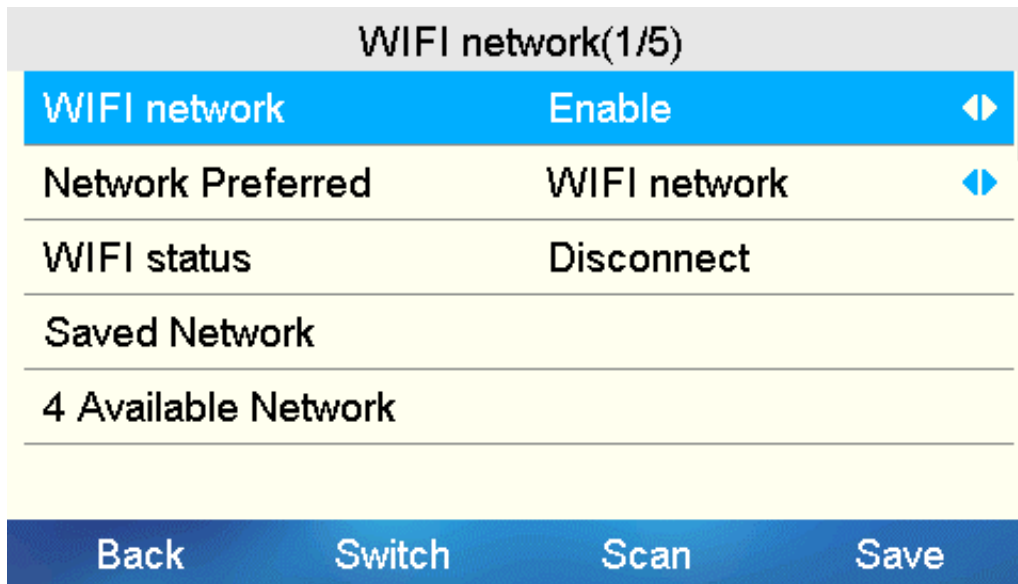

Figure 2.2-2

3. Press the *Left/Right* navigation key or *Switch* key to enable or disable WiFi network;
4. Press the *UP/Down* navigation key to select Network Preferred, and press the *Left/Right* navigation key or *Switch* key to setup Network Priority (you can select WIFI Network or Wired Network);
5. Press the *Scan* key to scan Available Networks;
6. Press the *UP/Down* navigation key and then press *Enter* key to enter the Available Network menu;

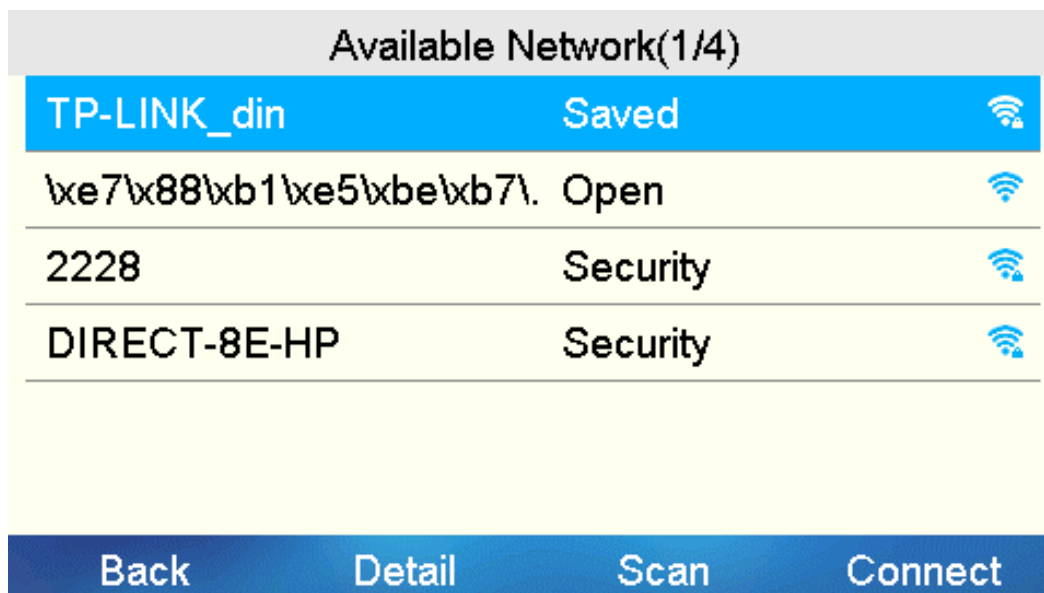

Figure 2.2-3

7. Press the *UP/Down* navigation key to select the desired WiFi Network (please make sure this WiFi network is secure), and then press the *Connect* key;
8. After entering the correct WiFi password, press the *OK* key. Once the password

is verified correctly, IP Phone can connect to the WiFi Network.

The image shows a mobile device screen with a grey header bar at the top containing the text "Enter Password(1/1)". Below the header is a yellow background area with the label "Password:" followed by a blue-outlined rectangular input field. At the bottom of the screen is a dark blue navigation bar with four white buttons labeled "Back", "abc", "Delete", and "OK".

Figure 2.2-4

Note: You can also press [Menu->Settings->Basic Setting->WiFi network](#) to enter the WiFi network menu. Then you can configure the WiFi network according to steps 3-8 above.

2.2.2 Configuring WiFi Network through web

2.2.2.1 Check the status of Wi-Fi network

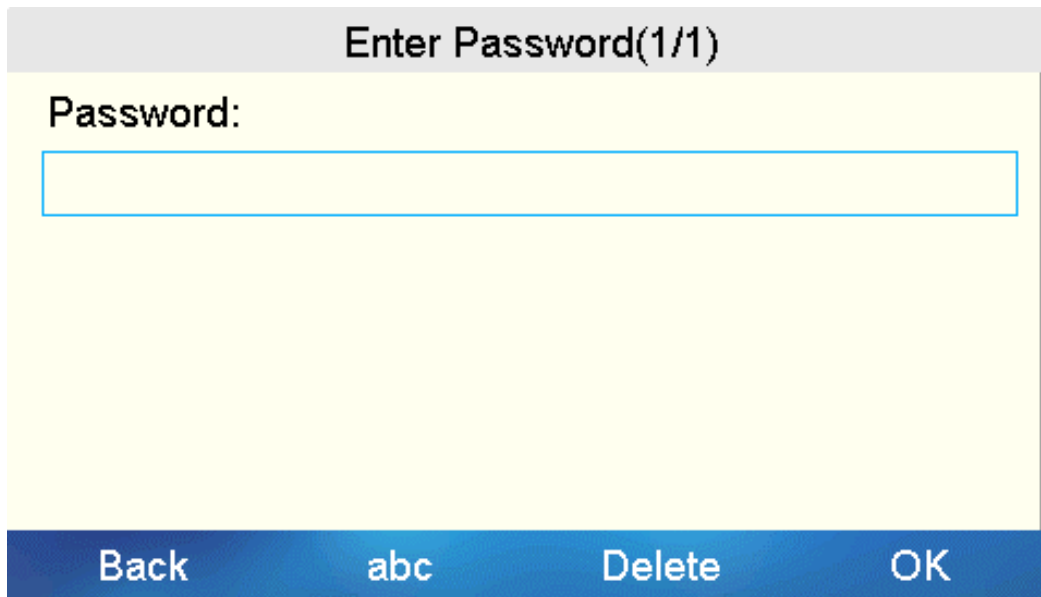
Firstly, you need to check the IP address of the IP Phone and log in to the web system:

1. Press the [OK](#) key to view the IP address of the IP Phone;
2. Input the IP address of the phone (such as <http://172.16.1.111>) in the browser address box and press Enter;
3. After logging in to the web system, you can go to [Status->Wi-Fi](#) Status to check the WiFi Network status.

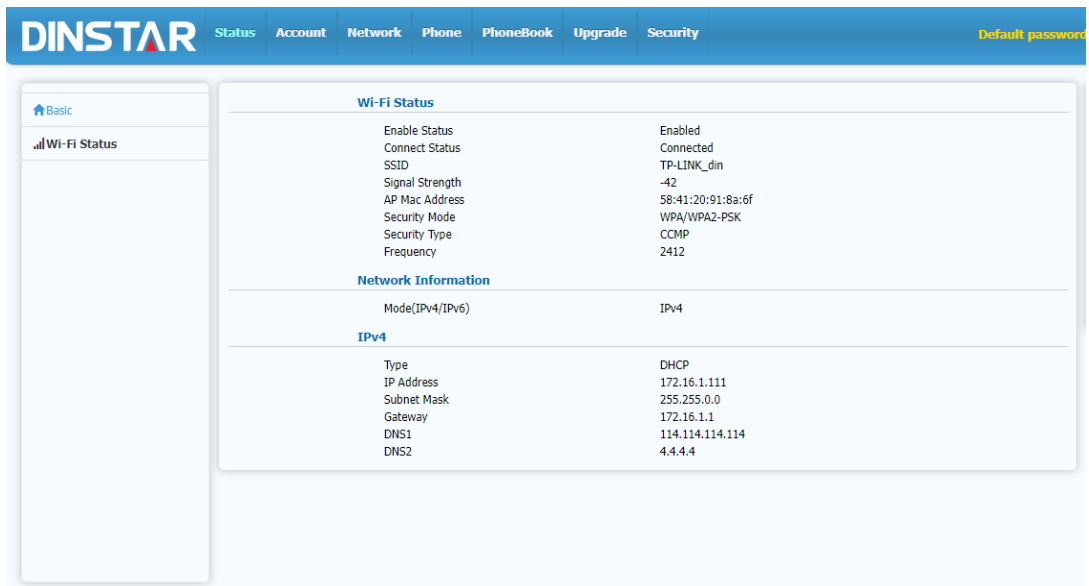

Figure 2.2-5

Sections	Description
Wi-Fi Status	It provides the information of WiFi Status such as Enable Status, Connect Status, SSID, Signal Strength, AP Mac Address, Security Mode, Security Type and Frequency.
Network Information	Show you the network mode of WiFi Network.
IPv4	It provides the information of the IPv4 such as Type(DHCP/Static IP), IP Address, Subnet Mask, Gateway, DNS1 and DNS2.

2.2.2.2 Configure the WiFi network

You can go to [Network->Wi-Fi](#) to configure the IP address and Network Priority of the WiFi network. And you can also directly enter the SSID and password of the WiFi on this page.

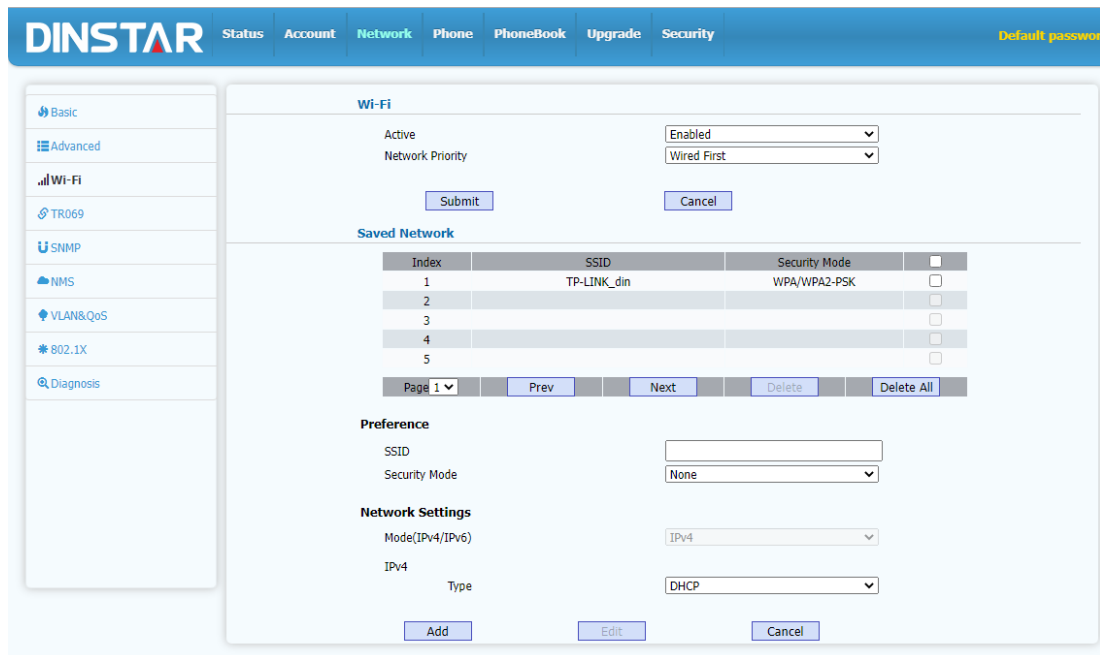

Figure 2.2-6

Sections	Description
Wi-Fi	To configure the Active and Network Priority of the WiFi Network.
Saved Network	<p>You can configure Preference and Network settings.</p> <p>Preference includes SSID and Security Mode.</p> <p>Network settings includes:</p> <ul style="list-style-type: none"> • Mode(IPv4/IPv6) • Type(DHCP/Static IP) • IP Address • Subnet Mask • Default Gateway • DNS1 • DNS2

2.3 Connecting IP Phone to Bluetooth Headset

2.3.1 Configuring the Bluetooth through IP Phone (take C66 IP phone for example)

1. After inserting the WiFi+Bluetooth adapter into the USB port of the IP Phone. The screen will pop up a prompt message "USB adapter has been inserted, Scan Network?";

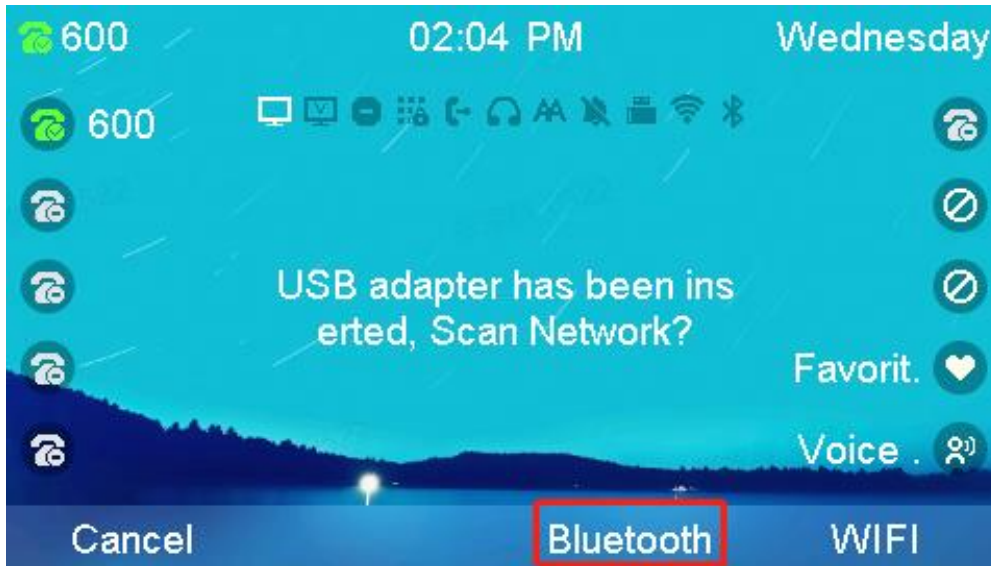

Figure 2.3-1

2. Press the *Bluetooth* key to enter the Bluetooth scanning page (please keep the Bluetooth headset on and in the pairing mode. Usually there is an indicator light when Bluetooth is on pairing mode, please read the Bluetooth headset operation instructions for details).

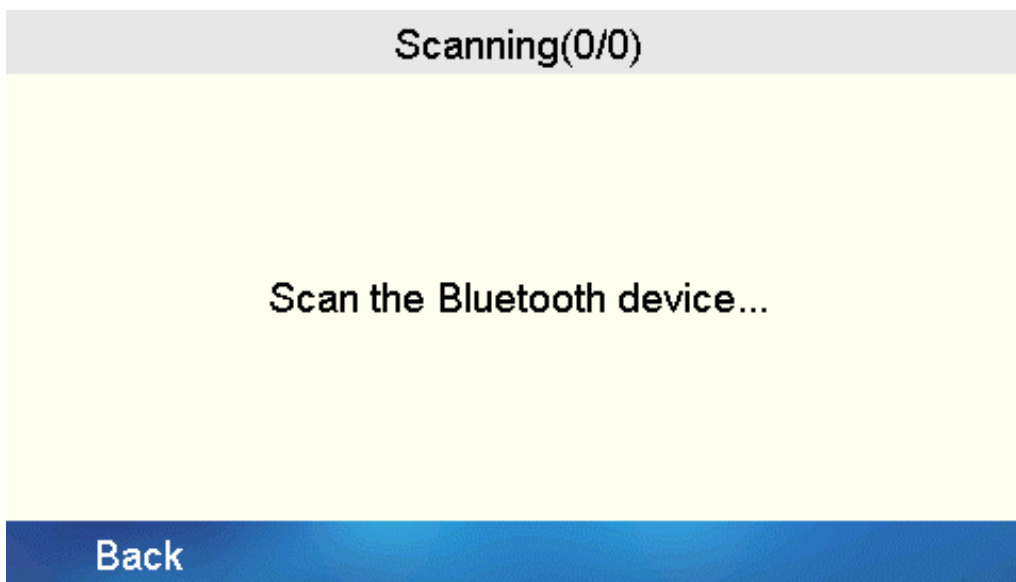





Figure 2.3-2

3. Press the *Up/Down* navigation key in the scanning list to select the desired Bluetooth device;

Scanning(5/5)		
OPPO Find X3 Pro	FC:04:1C:1B:20:84	
Jabra Elite 2	2C:E0:32:C9:15:04	
Redmi	24:11:45:89:1C:06	
vivo	54:19:C8:79:2B:41	

Back Connect

Figure 2.3-3

4. Press the *Connect* key to connect the Bluetooth device, and the icon will change to "√" after successful connection.

Notes: You can also press *Menu->Settings->Basic Setting->Bluetooth* to configure Bluetooth:

1. Press the *Left/Right* navigation key or *Switch* key to enable or disable the Bluetooth;
2. Press the *Up/Down* navigation key to select BT Headset Priority, and then press the *Left/Right* navigation key or *Switch* key to enable or disable BT Headset Priority;
3. Press the *Up/Down* navigation key to select Device Info, and press *Save* key to modify Bluetooth device name and Mac, and then press *Save* key;
4. Press *Up/Down* navigation key to enter the paired device menu, press *Info* key to view the details of the paired device, press *Delete* key to delete the Bluetooth device, and press *Disconnect* key to disconnect from the paired device.

2.3.2 Configuring Bluetooth through web

You can go to Phone->Basic to configure the Bluetooth, and you can enable or disable the Ring From Headset and BT Headset Priority.

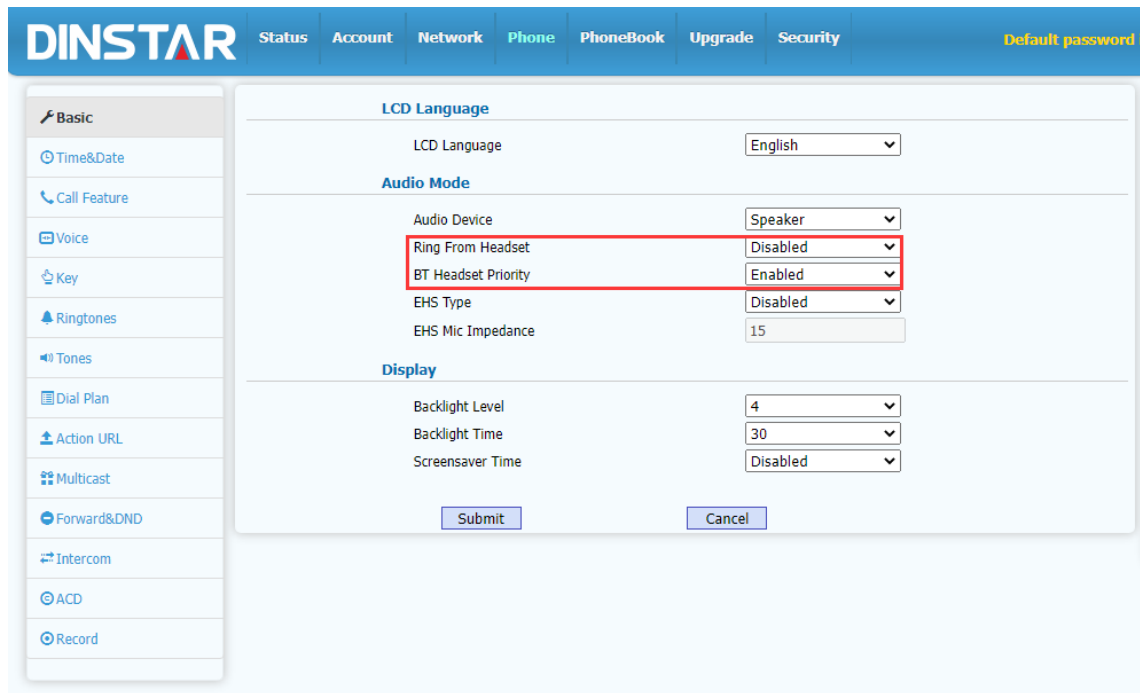
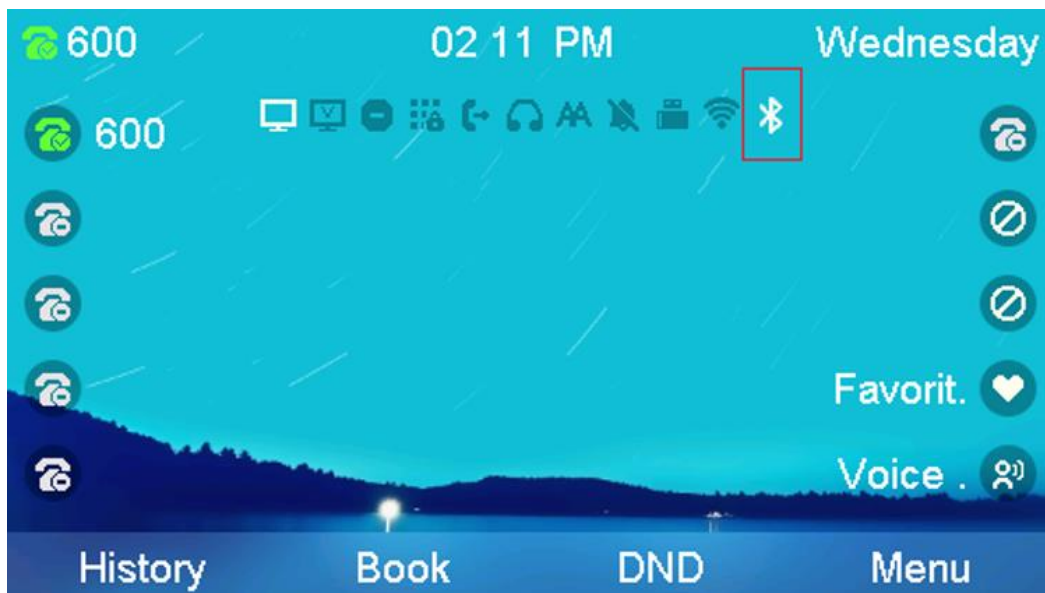

Figure 2.3-4

2.3.3 Answering/making calls with Bluetooth headset

1. When the Bluetooth headset is successfully connected, you can see the activated Bluetooth icon on the main screen of the IP Phone;



2. If there is an incoming call, you can hear the ringing tone through the Bluetooth headset. And then click the answer button of the headset (the answer operation of each headset may be different, please read the Bluetooth headset operation instructions for details).
3. After then, you can use the Bluetooth headset to make a conversation. At the same time, the headset icon is also activated. When the call is over, click the

hang-up button of the headset to end the call.

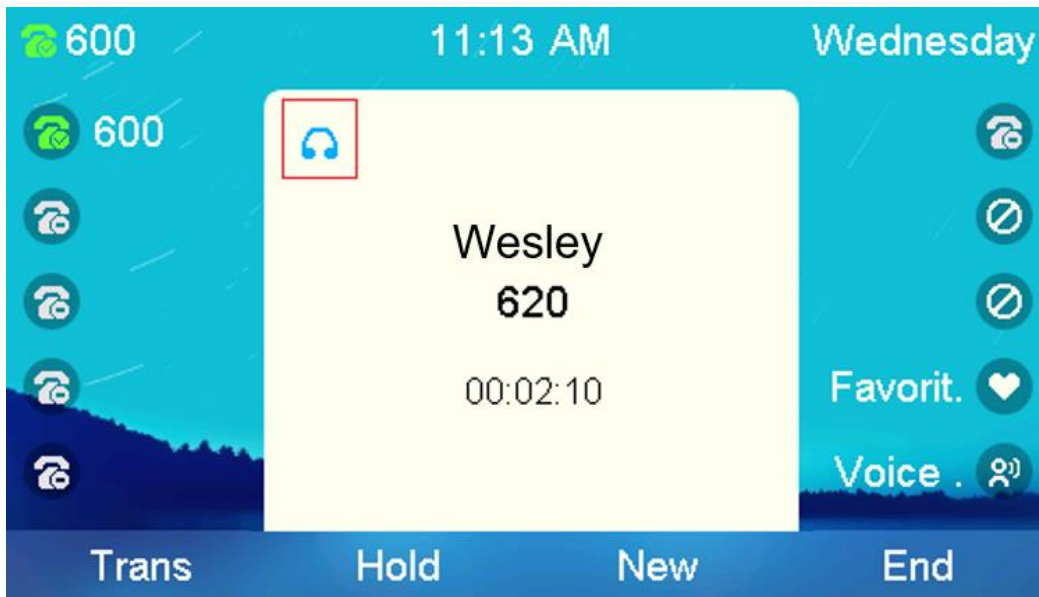

1. After the call is ended, the headset icon is still activated, so you can directly enter the callee number to make a call.
2. When entering the number or creating a call, you can hear the keyboard tones and ringback tone through the bluetooth headset. After the other party answers, you can use the bluetooth headset to start conversation.

3 Troubleshooting

3.1 Why can't the IP phone connect to the WiFi network?

- If the WiFi Network is secure, please make sure that the entered password is correct.
- Turn off the Wi-Fi feature of the IP phone, and then turn it on again.

3.2 Why is the WiFi signal strength low?

- Please make sure that both the IP phone and your gateway/router are in working range.

3.3 Why can't the IP Phone detect the Bluetooth Headset?

- Firstly, please make sure that the Bluetooth Headset is in pairing mode. And then make sure your IP Phone and the Bluetooth Headset are in the working range of 10 meters(32 feet).