

# WB10 Wireless Adapter

## Overview

WB10 Wireless Adapter is used with Dinstar SIP phones and supports IEEE802.11B, IEEE802.11G, IEEE802.11N wireless WLAN transmission standards, its WIFI maximum transmission rate of up to 150Mbps.

WB10 Wireless Adapter supports Clear Channel Assessment (CCA). When the surrounding wireless signal interference occurs, it can filter the interference. So that the wireless signal is more stable. When the interference has been gone, it can also automatically bundle the free channels, make full use of the bundle advantage to improve wireless performance.

## WB10 Wireless Adapter



## Key Features

- Compatible with Dinstar IP Phone C64GP-C66GP
- Reliable Connection
- High Transmission Rate, Plug and Play
- Supports 802.11N wireless devices, Compatible with 802.11 B/G/N
- Supports WPA, WPA2, Hardware-based AES and TKIP
- Supports Adaptive Frequency Hopping
- Perfectly compatible with Bluetooth v4.0+EDR
- Compatible with Bluetooth v1.1 and v1.2

## Bluetooth

### Adaptive Frequency Hopping

**Bluetooth Version:** V4.0

**Interface:** USB1.1/USB2.0

**Transmission Distance:** 10m

**RF Power:** 10dBm (Maximum)

**Antenna Type:** Integrated

**Transmission Speed:** 3M/S

## Physical Character:

**Dimension (L\*W\*H):** 16mm\*8m\*32mm

**Operating Temperature:** -20 °C ~ 45 °C

**Storage Temperature:** -40 °C ~70 °C

**Operating Humidity:**

10%-90% Non-Condensing

**Storage Humidity:**

5%-90% Non-Condensing

**Operating Current:**

5V=100mA~200mA(BT+WIFI)

**Power Consumption:**

0.5W~1W(BT+WIFI)

## WIFI

### Protocols:

IEEE 802.11n, IEEE 802.11g,

IEEE 802.11b, CSMA/CA with ACK

**Transmission Speed:** 150Mbps

**Frequency Range:** 2.4 ~ 2.4835GHz

**Operating Channel:** 1-14

### Modulation:

802.11 g/n: OFDM

802.11b:CCK(11, 5.5Mbps),

QPSK(2Mbps), BPSK(1Mbps)

### Transmission Rate:

802.11b: 11,5.5,2,1 Mbps

802.11g: 54,48,36,24,18,12,9,6 Mbps

802.11n: up to 150Mbps

## WIFI

### WEP, WPA/WPA2

**802.11i, 802.11x**

### Hardware-based AES and TKIP

### Receiving Sensitivity:

130M: -65dBm@10% PER

108M: -65dBm@10% PER

54M: -65dBm@10% PER

11M: -87dBm@8% PER

### Transmission Distance:

Up to 100m indoor

Up to 200m outdoor

(Depending on the environment)

**RF Power:** 16dBm (Maximum)

**Antenna Type:** Integrated

**Direct Sequence Spread Spectrum**

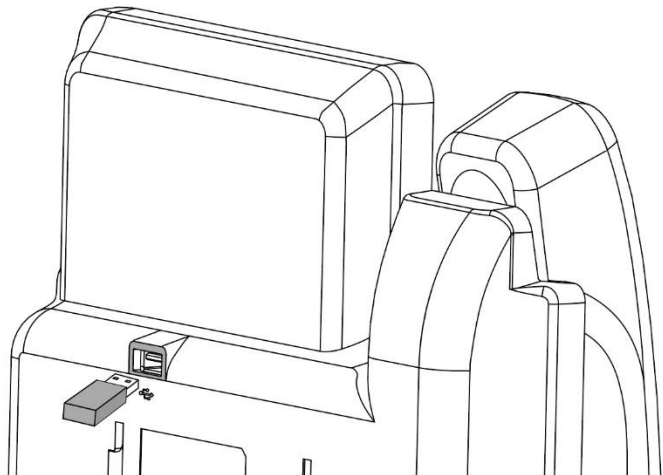

## Shenzhen Dinstar Co.,Ltd.

Floor 18, Building 7A, Vanke Cloud City Phase 1, Xingke 1st Street, Xili Sub-district, Nanshan District, Shenzhen, P.R. China 518000

www.dinstar.com  
sales@dinstar.com

**DINSTAR**

## About Us

Founded in 2011 in Shenzhen, DINSTAR is a leading global provider of IP Unified Communication products including VoIP Gateways, IP PBXs, IP Phones and SBCs, we have been delivering more agile, efficient and affordable communication solutions and unparalleled communication experiences to our customers with our reliable, innovative and future-proof products for years. Through our value-added distributors and resellers worldwide, now DINSTAR serves telecom operators, service providers, system integrators, enterprises, SMBs and OEM partners in over 100 countries.